

PUSH-IN FITTINGS

COMPACT CDC PNEUMATICS

PLUS

REDUCED DIMENSIONS to be easily used in confined spaces

ALSO AVAILABLE FOR TUBING
Ø3mm

OVAL LOCKING COLLET to improve disconnection

STATIC GRIPPING SYSTEM in order to stop all movement of the tube when inserted, granting a leak-proof connection

**MADE WITH TOP QUALITY
TECNOPOLYMERS** to guarantee long-lasting components



p. 35 / **PC-C-R**



p. 35 / **PC-C-G**



p. 35 / **POC-C-R**



p. 36 / **POC-C-M**



p. 36 / **PCF-C-M**



p. 36 / **PMM-C**



p. 37 / **PL-C-R**



p. 37 / **PL-C-G**



p. 37 / **PLL-C-R**



p. 38 / **PLL-C-M**



p. 38 / **PT-C-R**



p. 38 / **PT-C-M**



p. 39 / **PST-C-R**



p. 39 / **PST-C-M**



p. 39 / **PUC-C**



p. 40 / **PG-C**



p. 40 / **PUL-C**



p. 40 / **PUT-C**



p. 41 / **PY-C**



p. 41 / **PW-C**



p. 41 / **PGJ-C**





0°C ÷ 60°C



Working pressure:
10 Bar
Negative pressure:
- 0,95 Bar (- 95 kPa)



Compressed air & Vacuum
(do not use in water application)



- Taper gas BSPT ISO 7
R1/8"
- Parallel gas BSPP ISO 228
G1/8"
- Metric ISO 262
M3, M5 and M6



Polyamide PA,
Polyurethane PU,
Polypropylene PE



Body: PBT and nickel-plated brass
Collar: Nickel-plated brass
Collet: POM
Lock claw: Stainless steel AISI 301
Back ring: POM
Seal: NBR silicone free
O-ring: NBR silicone free

SILICONE FREE



Products in compliance with
EC Regulation 1907/2006

RoHS3

Products in compliance with
the directive EU 2015/863

CONSTRUCTION DETAILS

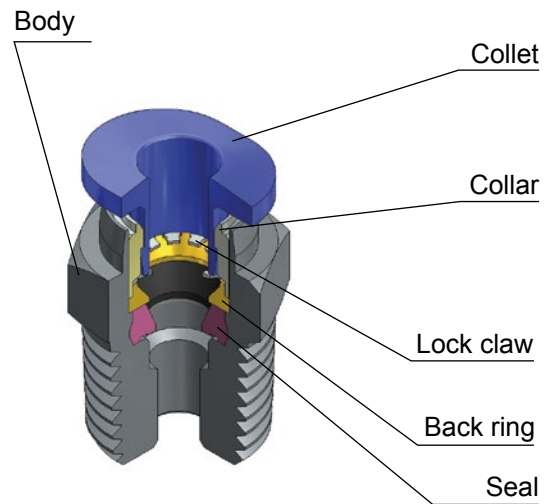
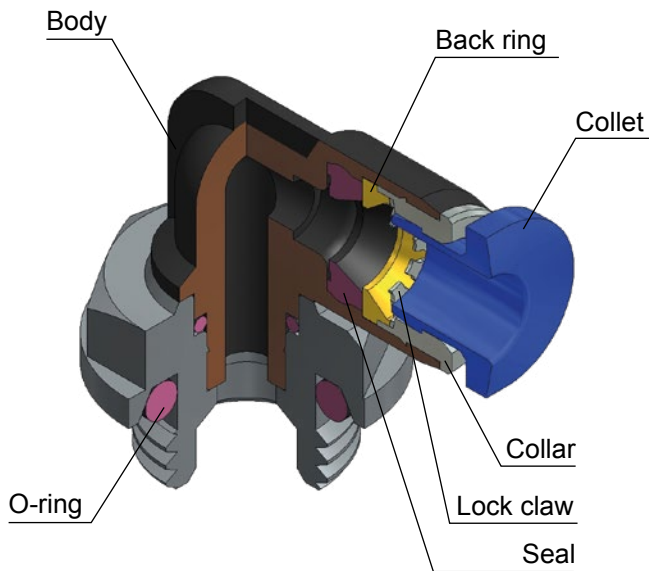

TIGHTENING TORQUE
TAPER GAS BSPT ISO 7

THREAD	1/8"
Nm	7

TIGHTENING TORQUE
PARALLEL GAS BSPP ISO 228 & METRIC ISO 262

THREAD	M3x0,5	M5x0,8	M6x1,0	1/8"
Nm	0,7	1,5	2,3	10



INSERTION OF THE TUBE INTO THE FITTING

- Make sure the tube is fully inserted into the fitting.
- To insert the tube into the fitting cut the tube off square (90°), insert tube up to the fitting end stop, and pull back gently to make sure it is correctly connected.
- If there is any damage or scratches on the tube surface the tube is an oval shape, air leakage and tube release may occur. Check the tube condition carefully.
- The OD of polyurethane tube expands when pressure is applied. Reinsertion into the fitting may not always be possible. Check the OD of the tube and renew it the expansion is out of tolerance.

DISCONNECTION OF THE TUBE FROM THE FITTING

- Make sure the pressure in the system is zero before releasing the tube from the fitting.
- To release the tube, press the release sleeve towards the fitting with one hand (1) and pull the tube away from the fitting with the other hand (2).
- Always remove the section of tube previously inserted into the fitting before reinserting the tube by cutting back the tube. Always use the correct tube cutter in order to cut the tube square and free of damage.

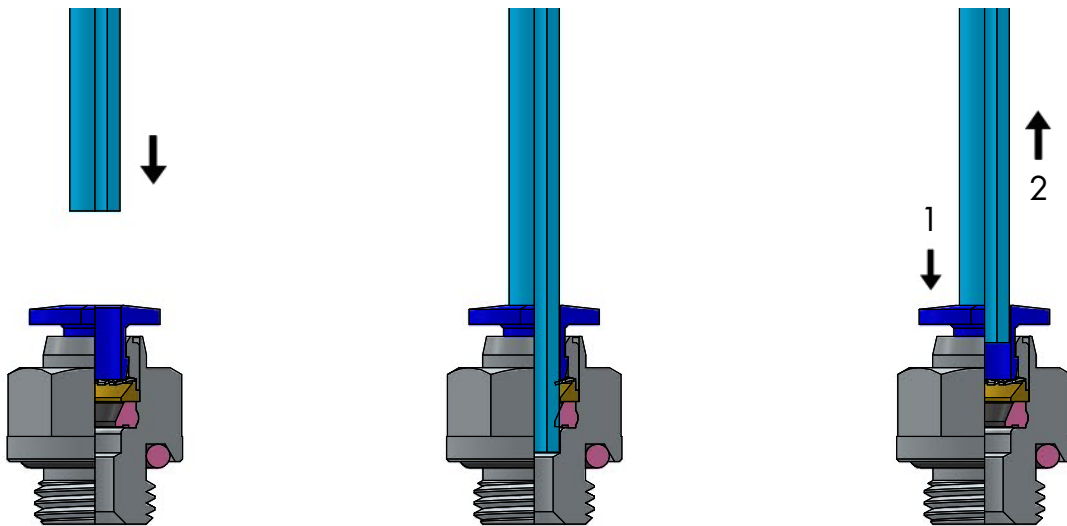

TOLERANCES - METRIC TUBE

Ø TUBE (mm)	3	4	6
TOLERANCE (mm)	± 0,1	± 0,1	± 0,1

INSERTION DEPTH - METRIC TUBE

Ø TUBE (mm)	3	4	6
TUBE INSERTION LENGHT (mm)	11,3	11,8	12,9



PC-C-R

Compact male connector BSPT thread nickel-plated

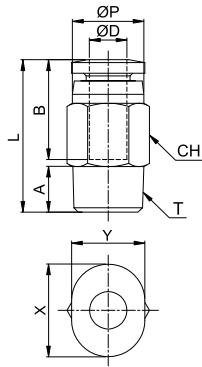

CODE	ØD	T	ØP	A	B	L	CH	X	Y	DN	g
PC-C04R01	4	R1/8"	8,0	8,0	11,7	16,7	10	10,4	8,2	3,0	6,0
PC-C06R01	6	R1/8"	10,0	8,0	12,7	18,9	10	12,4	10,2	5,0	7,0

PC-C-G

Compact male connector BSPP & metric thread nickel-plated

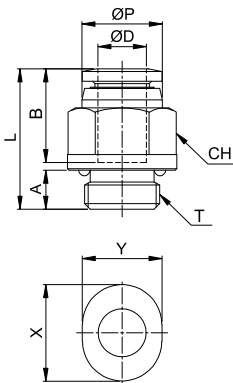

CODE	ØD	T	ØP	A	B	L	CH	X	Y	DN	g
PC-C03M3	3	M3x0,5P	7,0	3,0	11,2	16,1	7	9,2	7,2	1,5	3,0
PC-C03M5		M5x0,8P	7,2	3,6	11,2	16,3	8	9,2	7,2	2,0	4,0
PC-C03M6		M6x1,0P	7,2	4,1	11,2	16,3	8	9,2	7,2	2,0	4,0
PC-C04M3	4	M3x0,5P	8,0	3,0	11,7	16,8	8	10,4	8,2	1,5	4,0
PC-C04M5		M5x0,8P	8,0	3,6	11,7	17,1	8	10,4	8,2	2,5	4,0
PC-C04M6		M6x1,0P	8,0	4,1	11,7	17,7	8	10,4	8,2	3,0	4,0
PC-C04G01	6	G 1/8"	8,3	5,0	11,7	17,4	12	10,4	8,2	3,0	8,0
PC-C06M5		M5x0,8P	10,0	3,6	12,7	18,6	10	12,4	10,2	2,5	5,0
PC-C06M6		M6x1,0P	10,0	4,1	12,7	18,9	10	12,4	10,2	3,0	6,0
PC-C06G01		G 1/8"	10,3	5,0	12,7	17,9	12	12,4	10,2	5,0	9,0

POC-C-R

Compact male connector round body with internal hexagon BSPT thread nickel-plated

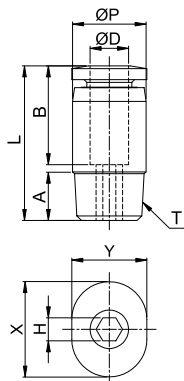

CODE	ØD	T	ØP	A	B	L	H	X	Y	DN	g
POC-C04R01	4	R 1/8"	10	8,0	11,7	15,7	3	10,4	8,2	3,0	5,0
POC-C06R01	6	R 1/8"	10	8,0	12,7	18,9	4	12,4	10,2	4,0	6,0

POC-C-M

Compact male connector round body with internal hexagon metric thread nickel-plated

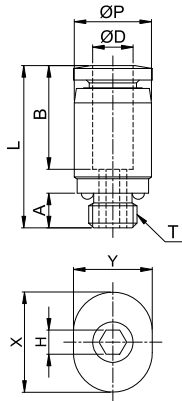

CODE	ØD	T	ØP	A	B	L	H	X	Y	DN	g
POC-C03M3	3	M3x0,5P	7	3,0	11,2	16,1	1,5	9,2	7,2	1,5	2,0
POC-C03M5		M5x0,8P	7	3,6	11,2	16,3	2,0	9,2	7,2	2,0	2,0
POC-C03M6		M6x1,0P	8	4,1	11,2	16,7	2,0	9,2	7,2	2,0	4,0
POC-C04M3	4	M3x0,5P	8	3,0	11,7	16,8	1,5	10,4	8,2	1,5	3,0
POC-C04M5		M5x0,8P	8	3,6	11,7	16,9	2,5	10,4	8,2	2,5	4,0
POC-C04M6		M6x1,0P	8	4,1	11,7	17,2	3,0	10,4	8,2	3,0	4,0
POC-C06M5	6	M5x0,8P	10	3,6	12,7	18,6	2,5	12,4	10,2	2,5	5,0
POC-C06M6		M6x1,0P	10	4,1	12,7	18,6	3,0	12,4	10,2	3,0	5,0

PCF-C-M

Compact female connector metric thread nickel-plated

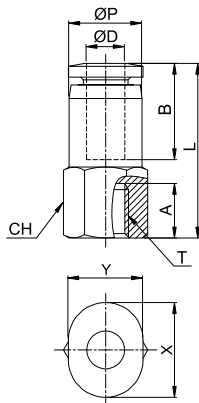

CODE	ØD	T	ØP	A	B	L	CH	X	Y	DN	g
PCF-C03M3	3	M3x0,5P	7,5	4,0	11,2	16,2	8	9,2	7,2	2,5	2,0
PCF-C03M5		M5x0,8P	7,5	6,0	11,2	18,7	8	9,2	7,2	2,5	2,0
PCF-C03M6		M6x1,0P	7,5	6,0	11,2	18,7	8	9,2	7,2	2,5	2,4
PCF-C04M3	4	M3x0,5P	8,0	4,0	11,7	17,7	8	10,4	8,2	2,5	3,0
PCF-C04M5		M5x0,8P	8,0	6,0	11,7	19,2	8	10,4	8,2	3,0	4,0
PCF-C04M6		M6x1,0P	8,0	6,0	11,7	19,2	8	10,4	8,2	3,0	4,0
PCF-C06M5	6	M5x0,8P	10,0	6,0	12,7	19,7	10	12,4	10,2	4,0	5,0
PCF-C06M6		M6x1,0P	10,0	6,0	12,7	19,7	10	12,4	10,2	4,0	5,0

PMM-C

Compact bulkhead connector nickel-plated

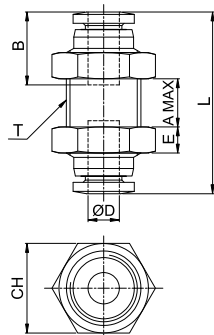

CODE	ØD	T	B	A MAX	L	E	CH	DN	g
PMM-C03	3	M8x0,75P	11,2	7,1	23,4	3,0	10	2,0	6,0
PMM-C04	4	M10x1,0P	11,7	6,5	24,3	3,5	12	3,0	10,0
PMM-C06	6	M12x1,0P	12,7	8,0	26,9	4,0	14	5,0	14,0



PL-C-R

Compact swivel male elbow BSPT thread nickel-plated

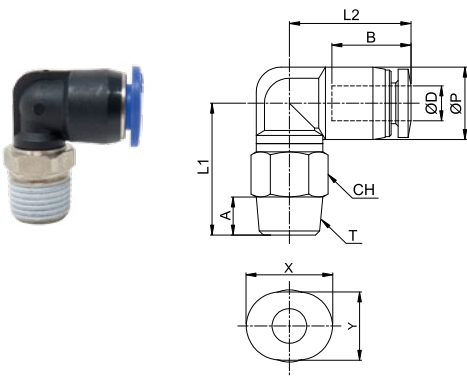

CODE	ØD	T	ØP	A	B	L1	L2	CH	X	Y	DN	g
PL-C04R01	4	R 1/8"	8,7	8,0	11,8	16,4	14,6	10	10,4	8,2	3,0	7,0
PL-C06R01	6	R 1/8"	10,8	8,0	12,8	17,4	15,5	10	12,4	10,2	3,0	7,0

PL-C-G

Compact swivel male elbow BSPP & metric thread nickel-plated

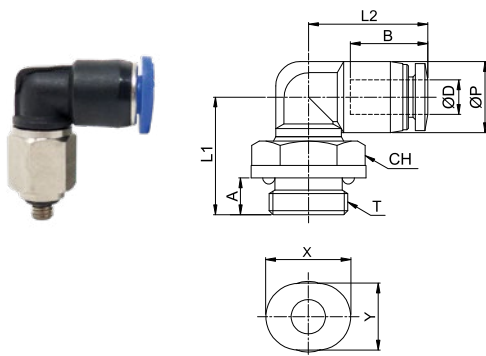

CODE	ØD	T	ØP	A	B	L1	L2	CH	X	Y	DN	g
PL-C03M3	3	M3x0,5P	7,6	3,0	11,3	14,7	13,5	8	9,2	7,2	1,5	4,0
PL-C03M5		M5x0,8P	7,6	3,6	11,3	15,3	13,5	8	9,2	7,2	2,5	4,0
PL-C03M6		M6x1,0P	7,6	4,1	11,3	15,8	13,5	8	9,2	7,2	2,5	4,0
PL-C04M3	4	M3x0,5P	8,7	3,0	11,8	15,3	14,6	8	10,4	8,2	1,5	4,0
PL-C04M5		M5x0,8P	8,7	3,6	11,8	15,9	14,6	8	10,4	8,2	2,5	4,0
PL-C04M6		M6x1,0P	8,7	4,1	11,8	16,4	14,6	8	10,4	8,2	3,0	4,0
PL-C04G01		G 1/8"	8,7	4,5	11,8	14,4	14,6	14	10,4	8,2	3,0	7,0
PL-C06M5	6	M5x0,8P	10,8	3,6	12,9	16,9	15,5	8	12,4	10,2	2,5	4,0
PL-C06M6		M6x1,0P	10,8	4,1	12,9	17,4	15,5	8	12,4	10,2	3,0	5,0
PL-C06G01		G 1/8"	10,8	4,5	12,9	15,4	15,5	14	12,4	10,2	3,0	6,0

PLL-C-R

Compact long swivel male elbow BSPT thread nickel-plated

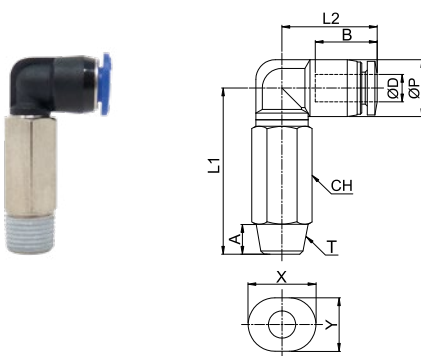

CODE	ØD	T	ØP	A	B	L1	L2	CH	X	Y	DN	g
PLL-C04R01	4	R 1/8"	8,7	8,0	11,8	29,4	14,6	10	10,4	8,2	3,0	13,0
PLL-C06R01	6	R 1/8"	10,8	8,0	12,8	32,4	15,5	10	12,4	10,2	3,0	14,0

PLL-C-M

Compact long swivel male elbow metric thread nickel-plated

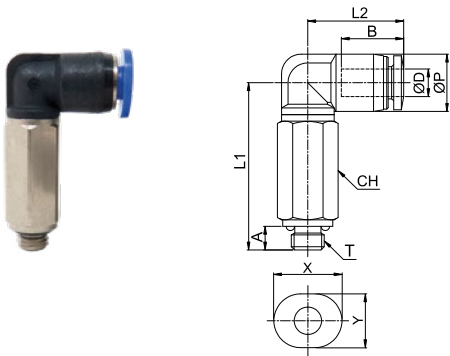

CODE	ØD	T	ØP	A	B	L1	L2	H	X	Y	DN	g
PLL-C03M3	3	M3x0,5P	7,5	3,0	11,3	21,8	13,5	8	9,2	7,2	1,5	6,0
PLL-C03M5		M5x0,8P	7,5	3,6	11,3	23,9	13,5	8	9,2	7,2	2,5	7,0
PLL-C03M6		M6x1,0P	7,5	4,1	11,3	24,4	13,5	8	9,2	7,2	2,5	7,0
PLL-C04M3	4	M3x0,5P	8,7	3,0	11,8	24,9	14,6	8	10,4	8,2	1,5	8,0
PLL-C04M5		M5x0,8P	8,7	3,6	11,8	25,5	14,6	8	10,4	8,2	2,5	8,0
PLL-C04M6		M6x1,0P	8,7	4,1	11,8	26,0	14,6	8	10,4	8,2	2,5	8,0
PLL-C06M5	6	M5x0,8P	10,8	3,6	12,8	28,4	15,5	8	12,4	10,2	2,5	9,0
PLL-C06M6		M6x1,0P	10,8	4,1	12,8	28,9	15,5	8	12,4	10,2	2,5	9,0

PT-C-R

Compact swivel male central tee BSPT thread nickel-plated

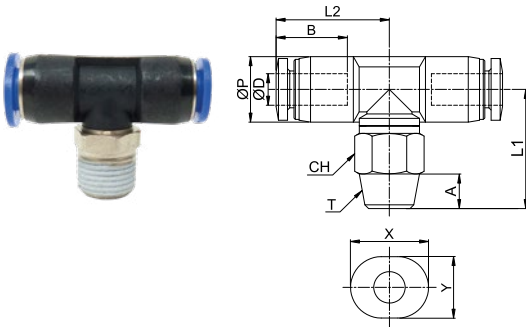

CODE	ØD	T	ØP	A	B	L1	L2	CH	X	Y	DN	g
PT-C04R01	4	R 1/8"	8,7	8,0	11,8	16,4	15,1	10	10,4	8,2	3,0	7,0
PT-C06R01	6	R 1/8"	10,8	8,0	12,8	17,4	16,0	10	12,4	10,2	3,0	9,0

PT-C-M

Compact swivel male central tee metric thread nickel-plated

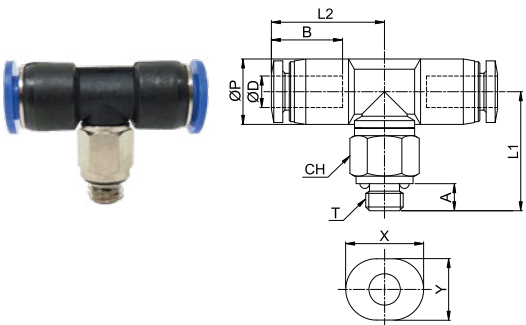

CODE	ØD	T	ØP	A	B	L1	L2	CH	X	Y	DN	g
PT-C03M3	3	M3x0,5P	7,6	3,0	11,3	14,7	14,5	8	9,2	7,2	1,5	4,0
PT-C03M5		M5x0,8P	7,6	3,6	11,3	15,3	14,5	8	9,2	7,2	2,5	5,0
PT-C03M6		M6x1,0P	7,6	4,1	11,3	15,8	14,5	8	9,2	7,2	2,5	5,0
PT-C04M3	4	M3x0,5P	8,7	3,0	11,8	15,3	15,1	8	10,4	8,2	1,5	5,0
PT-C04M5		M5x0,8P	8,7	3,6	11,8	15,9	15,1	8	10,4	8,2	2,5	5,0
PT-C04M6		M6x1,0P	8,7	4,1	11,8	16,4	15,1	8	10,4	8,2	3,0	6,0
PT-C06M5	6	M5x0,8P	10,8	3,6	12,8	16,9	16,0	8	12,4	10,2	2,5	7,0
PT-C06M6		M6x1,0P	10,8	4,1	12,8	17,4	16,0	8	12,4	10,2	3,0	7,0



PST-C-R

Compact swivel lateral male tee BSPT thread nickel-plated

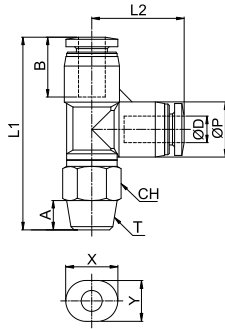

CODE	ØD	T	ØP	A	B	L1	L2	CH	X	Y	DN	g
PST-C04R01	4	R 1/8"	8,7	8,0	11,8	30,9	14,6	10	10,4	8,2	3,0	9,0
PST-C06R01	6	R 1/8"	10,8	8,0	12,8	33,9	16,5	10	12,4	10,2	3,0	10,0

PST-C-M

Compact swivel lateral male tee metric thread nickel-plated

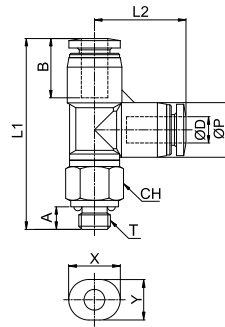

CODE	ØD	T	ØP	A	B	L1	L2	CH	X	Y	DN	g
PST-C03M3	3	M3x0,5P	7,6	3,0	11,3	28,3	13,6	8	9,2	7,2	1,5	4,0
PST-C03M5		M5x0,8P	7,6	3,6	11,3	28,9	13,6	8	9,2	7,2	2,5	5,0
PST-C03M6		M6x1,0P	7,6	4,1	11,3	29,4	13,6	8	9,2	7,2	2,5	5,0
PST-C04M3	4	M3x0,5P	8,7	3,0	11,8	29,8	14,6	8	10,4	8,2	1,5	5,0
PST-C04M5		M5x0,8P	8,7	3,6	11,8	30,4	14,6	8	10,4	8,2	2,5	6,0
PST-C04M6		M6x1,0P	8,7	4,1	11,8	30,9	14,6	8	10,4	8,2	3,0	6,0
PST-C06M5	6	M5x0,8P	10,8	3,6	12,8	33,4	16,5	8	12,4	10,2	2,5	7,0
PST-C06M6		M6x1,0P	10,8	4,1	12,8	33,9	16,5	8	12,4	10,2	3,0	7,0

PUC-C

Compact union connector

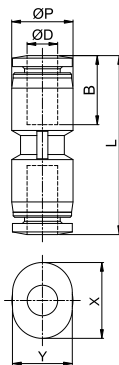

CODE	ØD	ØP	B	L	X	Y	DN	g
PUC-C03	3	7,5	11,4	23,8	9,2	7,2	2,4	3,0
PUC-C04	4	8,4	11,8	24,5	10,4	8,2	3,0	3,0
PUC-C06	6	10,6	12,9	26,8	12,4	10,2	4,0	3,0

PG-C

Compact reduced union connector

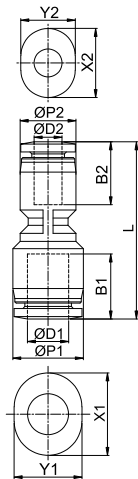

CODE	ØD1	ØD2	ØP1	ØP2	B1	B2	L	X1	Y1	X2	Y2	DN	g
PG-C0403	4	3	8,4	7,5	11,8	11,4	24,2	10,4	8,2	9,2	7,2	2,4	3,0
PG-C0603	6	3	10,6	7,5	12,9	11,4	26,3	12,4	10,2	9,2	7,2	2,5	3,0
PG-C0604	6	4	10,6	8,4	12,9	11,8	26,6	12,4	10,2	10,4	8,2	3,0	3,0

PUL-C

Compact union elbow

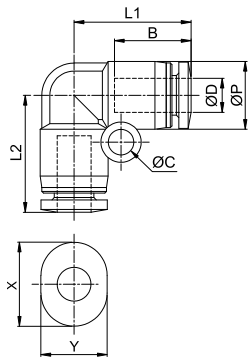

CODE	ØD	ØP	ØC	B	L1	L2	X	Y	DN	g
PUL-C03	3	7,5	3,2	11,4	17,3	17,3	9,2	7,2	2,4	2,0
PUL-C04	4	8,4	3,2	11,8	18,7	18,7	10,4	8,2	3,0	3,0
PUL-C06	6	10,6	3,2	12,9	21,9	21,9	12,4	10,2	4,0	3,0

PUT-C

Compact union tee

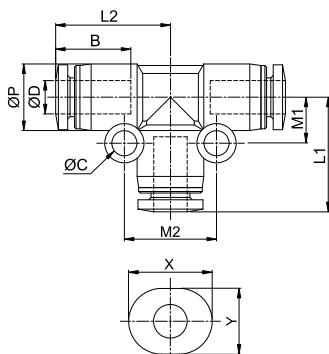

CODE	ØD	ØP	ØC	B	L1	L2	M1	M2	X	Y	DN	g
PUT-C03	3	7,5	3,2	11,4	17,3	27,2	5,3	10,7	9,2	7,2	2,4	3,0
PUT-C04	4	8,4	3,2	11,8	18,7	28,9	5,8	11,6	10,4	8,2	3,0	3,0
PUT-C06	6	10,6	3,2	12,9	21,9	33,2	6,9	13,8	12,4	10,2	4,0	6,0



PY-C

Compact union Y

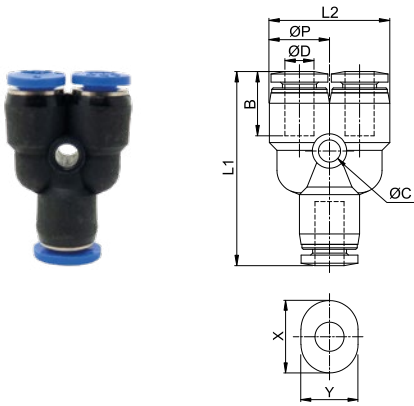

CODE	ØD	ØP	ØC	B	L1	L2	X	Y	DN	g
PY-C03	3	7,6	3,2	11,4	27,0	15,2	9,2	7,2	2,4	3,0
PY-C04	4	8,7	3,2	11,8	28,0	17,4	10,4	8,2	3,0	5,0
PY-C06	6	10,8	3,2	12,9	30,8	21,6	12,4	10,2	4,0	6,0

PW-C

Compact reduced union Y

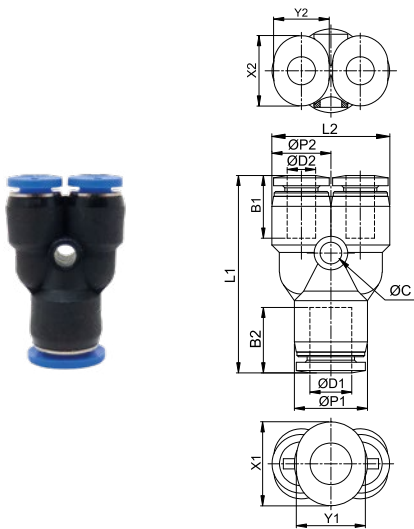

CODE	ØD1	ØD2	ØP1	ØP2	ØC	B1	B2	L1	L2	X1	X2	Y1	Y2	DN	g
PW-C0403	4	3	8,7	7,6	3,2	11,8	11,4	27,6	15,2	10,4	8,2	9,2	7,2	2,0	3,0
PW-C0603	6	3	10,8	7,6	3,2	12,9	11,4	28,8	15,2	12,4	10,2	9,2	7,2	2,4	4,0
PW-C0604	6	4	10,8	8,7	3,2	12,9	11,8	29,1	17,4	12,4	10,2	10,4	8,2	3,0	5,0

PGJ-C

Compact reduced

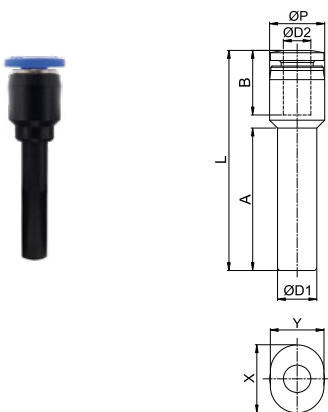

CODE	ØD1	ØD2	ØP	A	B	L	X	Y	DN	g
PGJ-C0403	4	3	7,6	18,0	11,4	30,5	9,2	7,2	2,4	1,0
PGJ-C0603	6	3	7,6	21,6	11,4	32,1	9,2	7,2	2,4	2,0
PGJ-C0604	6	4	8,4	21,8	11,8	33,7	10,4	8,2	3,0	3,0

